

NDM5-250V Moulded Case Circuit Breaker Product Specification

Product name: Moulded Case Circuit Breaker (MCCB)

Product model: NDM5-250V

Date: 2018-09-09

Prepared by	Wu Yali	Date	2018-09-09
Reviewed by	Xu Tao	Date	2018-09-09
Approved by	Gan Feiming	Date	2018-09-09

Revision History

Version	Revision Description	Revision Date	Revised by
0	Newly added file	20171211	Wu Yali
1	The mechanical life is changed to 25,000 times from 15,000 times	20180410	Wu Yali
2	1) Product picture add terminal cover. Specification model change("Nader" low voltage electrical apparatus, high voltage, breaking level code, release code). Main technical parameters: Increase the rated voltage by AC800V. Normal working environment : delete the average value within 24 hours doesn't exceed +35℃ and delete atmospheric conditions: ambient air temperature of +40℃, with a relative humidity of 95%;Increase in shape and size of terminal cover and insulation board. Reduction coefficient table update.	20180423	Wu Yali
3	The product power is changed from single phase power to single phase average power consumption . Undervoltage release removes AC110V/DC110V,AC400V. Shunt release removes AC48V/DC48V,AC110V/DC110V. Add the insulation board to the list of accessories.	20180909	Wu Yali

1 Applicable Scope and Purpose

The NDM5-250V series of moulded case circuit breakers (referred to as circuit breakers) have a rated insulation voltage of 1000V and apply to circuits with the AC 50Hz/60Hz, the rated working voltage of AC 1000V and rated working current (63A, 80A, 100A, 125A, 160A, 200A, 250A). The circuit breakers are used for distributing power while protect the overload, short circuit and under-voltage (with a under-voltage release) of lines and power units as well as the infrequent starting, braking, overload and short circuit of motors.

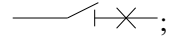
The circuit breaker has an isolating function with the corresponding symbol of ;

Comply with standards: IEC 60947-2, GB/T 14048.2.

2 Picture of the Product



3P Product

3 Specification and Model Description

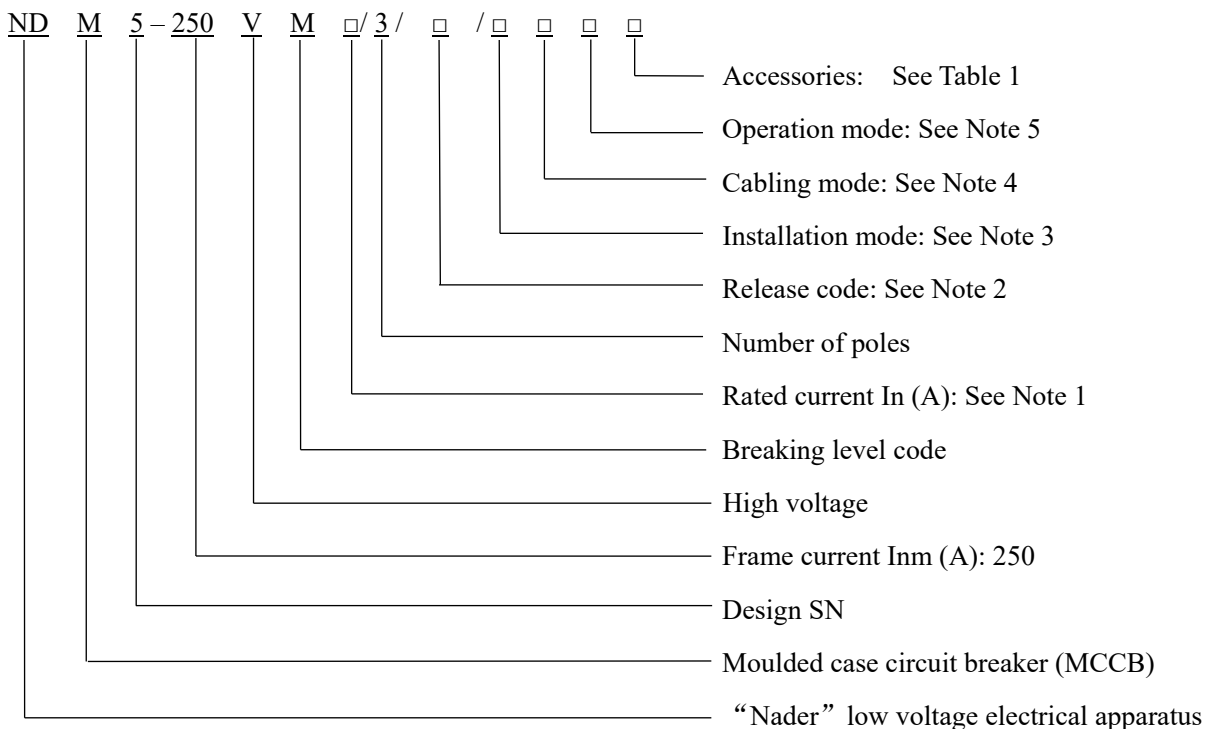

Note: 1) Rated current In (A): 63, 80, 100, 125, 160, 200, 250

2) Release code:

TMF (power distribution protection-thermal magnet-fixed) [Ir=In, Im=10In];

TMD (power distribution protection-thermal magnet-adjustable)

63A-125A: [thermo-adjustable (0.8-0.9-1.0) In, magnet-fixed];

160A-250A: [thermo-adjustable (0.8-0.9-1.0) In, magnet-adjustable (5-6-7-8-9-10) In]

3) Installation mode: fixed type: no code

4) Cabling mode: front connection: no code

5) Operation mode: direct handle-operated: no code; rotation handle operated: "R".

Table 1

Accessory code	Accessory name	Installation position
00	None	—
08	Alarm contact	
10	Shunt release	
30	Under-voltage release	
21	Single auxiliary contact	
61	Two sets of single auxiliary contacts	
23	Three sets of single auxiliary contacts	
18	Shunt release, alarm contact	
38	Under-voltage release, alarm contact	
22	Single auxiliary contact, alarm contact	
88	Two sets of single auxiliary contacts, alarm contact	
26	Three sets of single auxiliary contacts, alarm contact	
42	Shunt release, single auxiliary contact, alarm contact	
44	Shunt release, two sets of single auxiliary contacts, alarm contact	
46	Shunt release, three sets of single auxiliary contacts, alarm contact	
75	Under-voltage release, single auxiliary contact, alarm contact	
77	Under-voltage release, two sets of single auxiliary contacts, alarm contact	
81	Under-voltage release, three sets of single auxiliary contacts, alarm contact	
41	Shunt release, single auxiliary contact	
11	Shunt release, two sets of single auxiliary contacts	

12	Shunt release, three sets of single auxiliary contacts	
71	Under-voltage release, single auxiliary contact	
72	Under-voltage release, two sets of single auxiliary contacts	
73	Under-voltage release, three sets of single auxiliary contacts	

Note: Single auxiliary contact; Alarm contact;
 Shunt release Under-voltage release

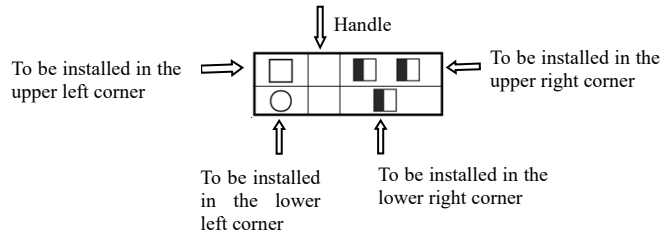

4 Main Technical Parameters

Frame current $I_{nm}(A)$	250	
Rated current $I_n(A)$	63,80,100, 125, 160, 200, 250	
Rated voltage $U_e (V)$	AC800, AC1000	
Utilization category	A	
Rated impulse withstand voltage $U_{imp} (V)$	8000	
Rated insulation voltage $U_i (V)$	1000	
Power frequency withstand voltage (1min) (V)	3500	
Rated frequency(Hz)	50/60	
Rated Ultimate breaking capacity $I_{cu} (kA)$	AC800V	50
	AC1000V	30
Rated Service breaking capacity $I_{cs} (kA)$	AC800V	35
	AC1000V	15
Life(times)	Mechanical life	15000
	Electrical life	1500

5 Normal Working Environment

- 2) Ambient air temperature: $-40^{\circ}C \sim +70^{\circ}C$;
- 3) Storage environment: $-40^{\circ}C \sim +75^{\circ}C$;
- 4) Altitude: $\leq 2000m$;
- 5) Class of pollution: 3;
- 6) Protection class: IP20;
- 7) Installation category: main circuit and under-voltage release: installation category III; auxiliary circuit and control circuit: installation category II;
- 8) The product can be disposed in places that are free from explosive media, media corrosive to metal, insulation damaging gas, and conductive dust.

9) The product should be installed free from snow and rain.

Note: The tripping parameters of circuit breakers are set according to the ambient temperature of +50°C; in case of the ambient temperature within +50°C ~ +70°C, users need to use the equipment for derating capacity. See "Derating Factor Table of Product Temperature Change" for the derating factory.

6 Tripping Characteristics

6.1 Tripping characteristics curve under normal environment (ambient air temperature: +50°C)

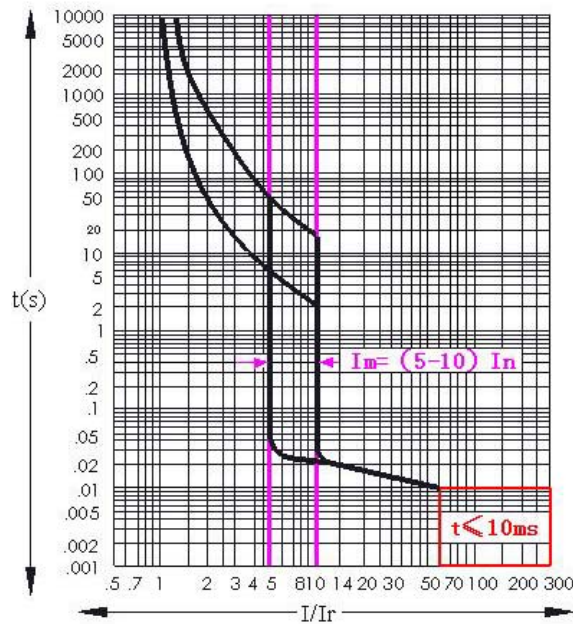

6.2 Parameter setting and function description of the thermo-magnetic adjustable AC distribution release

Setting gear of the overload long time-delay I_r	0.8 I_n , 0.9 I_n , 1.0 I_n	
Setting gear of the instantaneous short-circuit I_m	63A-125A	10 I_n (accuracy of $\pm 20\%$)
	160A-250A	5 I_n , 6 I_n , 7 I_n , 8 I_n , 9 I_n , 10 I_n (accuracy of $\pm 20\%$)
Action time	63A	1.05 I_n (cold state) doesn't operate within 1 hour, 1.3 I_n (thermal state) operate within 1 hour
	80A-250A	1.05 I_n (cold state) doesn't operate within 2 hours, 1.3 I_n (thermal state) operate within 2 hours
160A-250A features the thermo-magnetic parameter dual-adjustable functions and dual-display functions of overload and short-circuit fault actions.		

6.3 The tripping characteristics should be corrected due to small changes when the ambient air temperature varies

Ambient air temperature	Correction factor
40°C	1.0
45°C	1.0
50°C	1.0
55°C	0.93
60°C	0.88
65°C	0.86
70°C	0.83

Note: 1. The above derating factors are measured at the frame current;

2. When the operating ambient temperature is below +50°C, the product can be used normally, without requiring the derating capacity.

6.4 The tripping characteristics should be corrected due to small changes by considering the air insulation characteristics and cooling capacity with the ambient temperature of +50°C and the altitude above 2,000m.

Altitude (m)	2000	3000	4000	5000
Power frequency withstand voltage (V)	3500	3000	2500	2000
Average insulation class (V)	1Ui	1Ui	1Ui	0.95Ui
Maximum working voltage (V)	1Ue	1Ue	1Ue	0.95Ue
Average working current (A)	1In	0.96In	0.93In	0.9In

7 Product Outline and Installation Dimensions

7.1 External dimensions of products

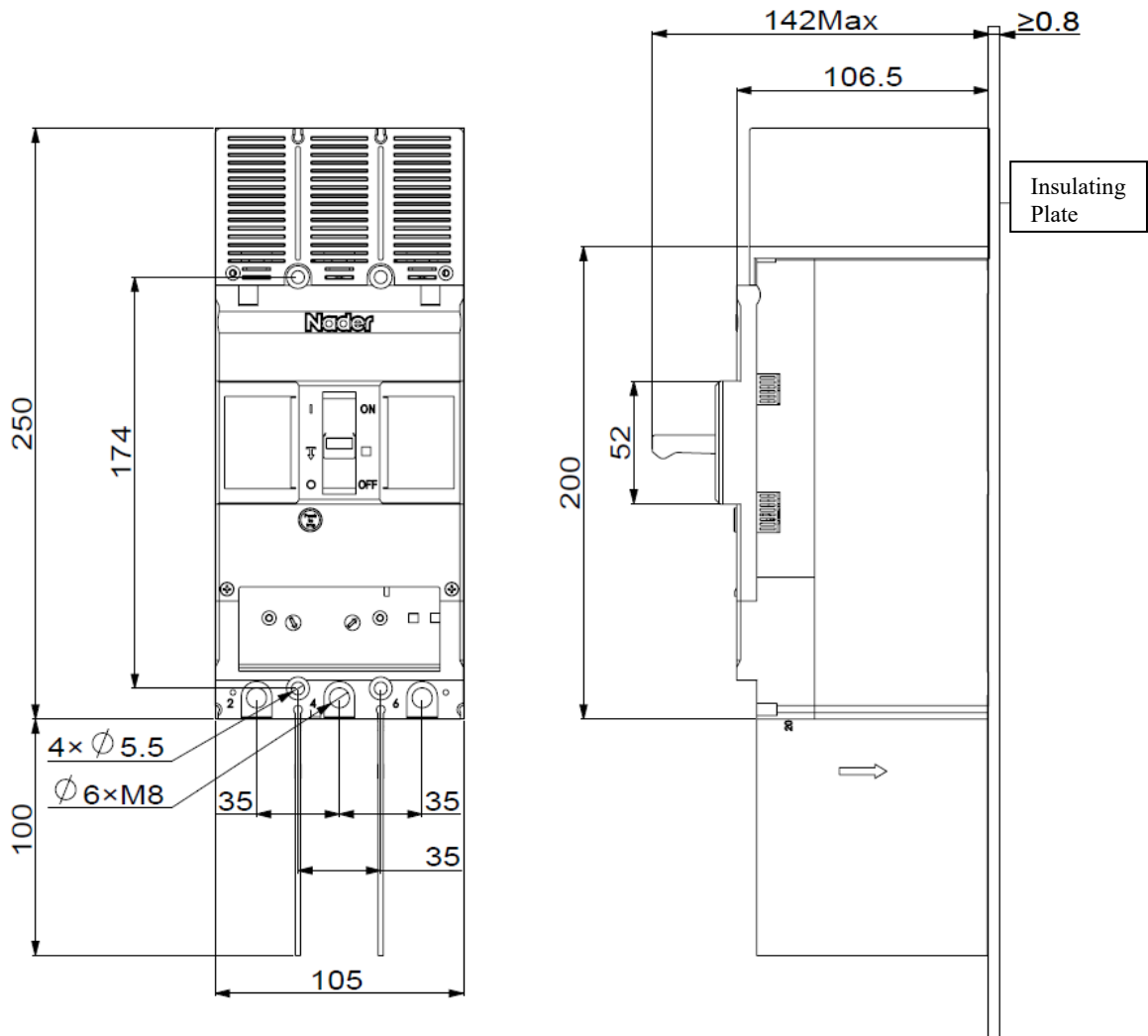

7.2 Product installation dimensions

7.2.1 Installed on the baseplate

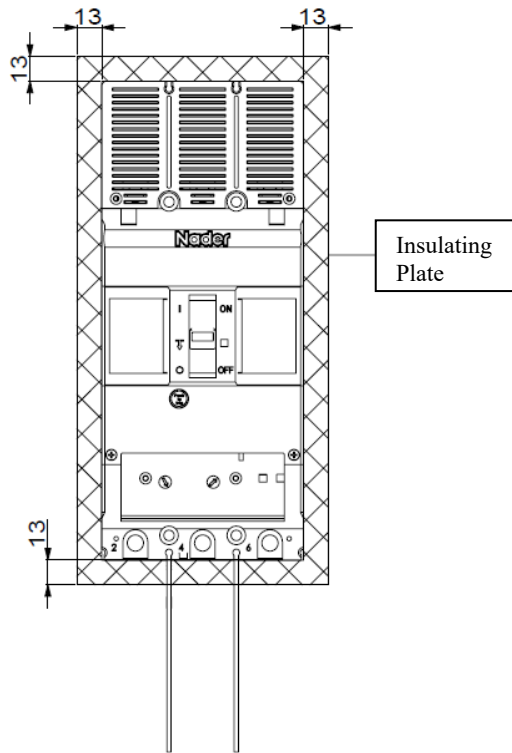

Insulating Plate Dimensions

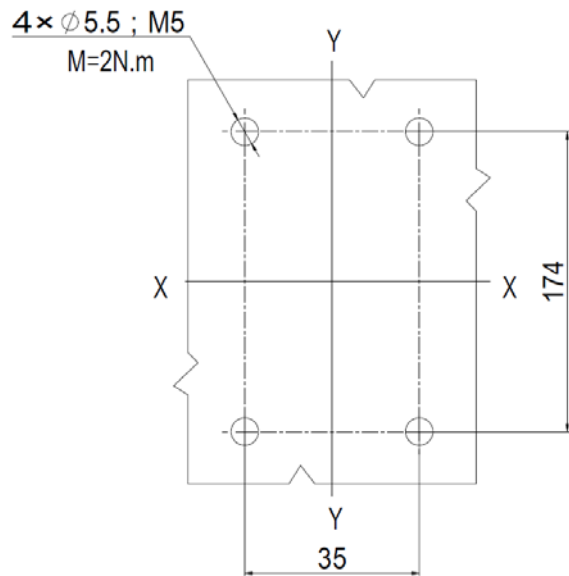

Mounting Hole Dimensions

7.2.2 Safety spacing

See the figure below for the minimum safety distance of the circuit breaker from the top, bottom, side and adjacent products during installation.

Safety Mounting Spacing between Circuit Breakers

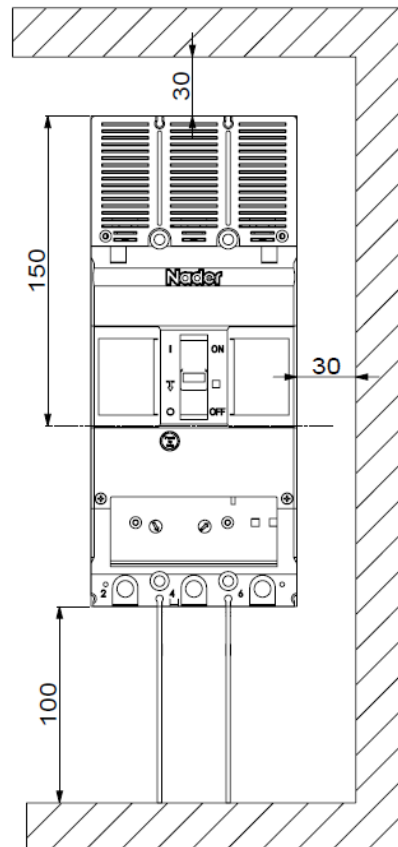
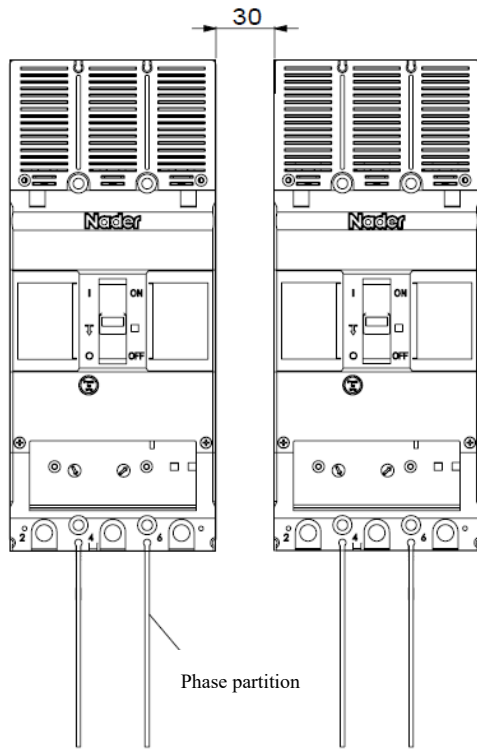

Notes: During use, a terminal cover and phase partition shall be installed respectively on the terminal side of 1, 3, 5 as well as 2, 4, 6 as shown in the figure. Besides, an insulating plate shall be inserted between the circuit breaker and the metal mounting plate

8 Installation Mode

The product allowable installation mode is shown as the figure below.

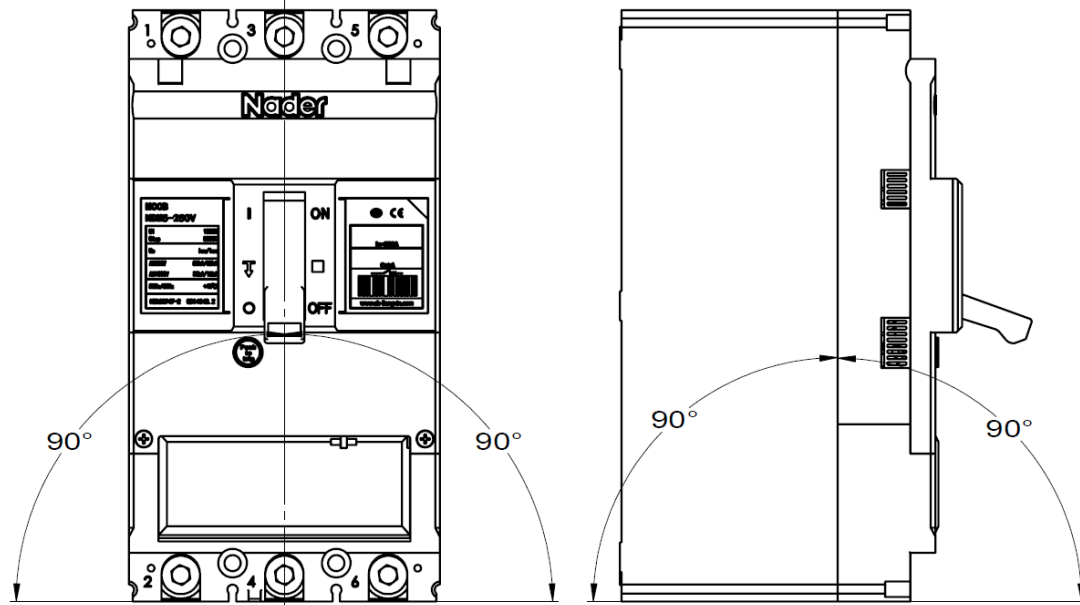

9 Product Power Consumption

Product model	Current specifications (A)	Single-phase average power consumption (W)
NDM5-250V	63	5
	80	8.3
	100	10
	125	7.8
	160	12.8
	200	20
	250	21.8

Note: The above data is the single power consumption of the circuit breaker measured at an ambient temperature of 40°C when the rated current is on.

10 Connection Capacity

Rated current (A)	63	80	100	125	160	200	250
Wire cross-section area (mm ²)	16	25	35	50	70	95	120
Tightening torque value of the terminal screw M8 (N.m)	15						

11 Operation Instructions for Accessories

11.1 Rated parameters of the auxiliary contact

Accessory name		Auxiliary contact
Voltage specifications (V)/conventional		AC250V/10A, DC220V/0.2A
Wiring diagram	Off	

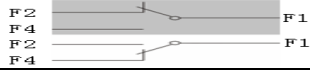
	On	
Internal resistance		<30 mΩ

11.2 Rated parameters of the alarm contact

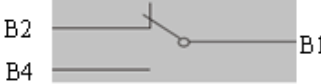
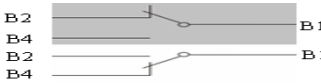
Accessory name		Alarm contact
Voltage specifications (V)/conventional		AC250V/3A, DC220V/0.2A
Wiring diagram	On, off	
	Free tripping	
Internal resistance		<30 mΩ

11.3 Under-voltage release

When the power voltage drops to the range (35%~70%) of the under-voltage release, the release can break the circuit breaker reliably; when the power voltage is 35% lower than the rated working voltage of the under-voltage release, the release can prevent closing of the circuit breaker; when the power voltage is 85% higher than the rated working voltage of the under-voltage release, the release can guarantee reliable closing of the circuit breaker

Voltage specifications of the under-voltage release: **AC230V/DC250V.**

Accessory name	Under-voltage release
Voltage specifications (V)	AC230/DC250
Power consumption (W)	1.0

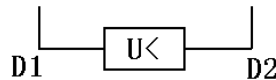

11.4 Shunt release

When the external voltage of the shunt release is between 70% and 110% of the rated control power voltage, the release can break the circuit breaker reliably.

Accessory name	Shunt release	
Voltage specifications (V)	AC24/DC24	AC230/DC250
Power consumption (W)	20	19

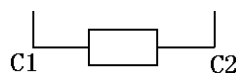

Working principle of the shunt release: a single pulse action. If another action is required, the shunt release can only be operated after being off, reset and energized.

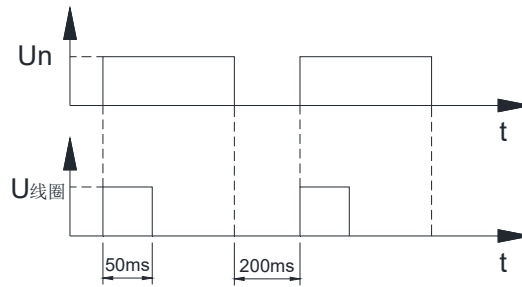

To make the circuit breaker fail to be closed normally during long-term energization, an auxiliary contact in series is required.



11.5 The standard wire length of the internal accessories (auxiliary contact, alarm contact, under-voltage release, shunt release) is 0.7m.

Note: Users must propose to the sales personnel of the special requirements of the accessory wire length.

12 Packaging and Storage

Minimum packaging quantity: 1 piece/box. The packaged products should be stored in a warehouse with the ambient temperature of $-40^{\circ}\text{C}\sim 75^{\circ}\text{C}$ and relative humidity below 80% without acidic, alkali or other corrosive gas in the surrounding air. Under the conditions above, the storage period shall be no more than 36 months since the manufacturing date.

13 List of accessories and installation

SN	Name	Specification	Quantity
1	Cross small pan-head screw	M5×110	4
2	Plain washer	5	4
3	Spring washer	5	4
4	Hexagon nut	M5	4
5	Phase partition	---	2
6	Insulating plate	---	1

14 Precautions

- 1) The performance parameters of this specification are suitable for normal conditions. For special requirements, put the equipment into use after consulting the company with formal confirmation and re-adjusting parameters by the company.
- 2) The circuit breaker, tripping unit or other accessories can only be installed and maintained by the trained or qualified professionals.
- 3) Ensure that the power supply is off before installing or removing any device.